

WIESEL™ SPEEDLine® WH80

with roller guideway and AT toothed belt

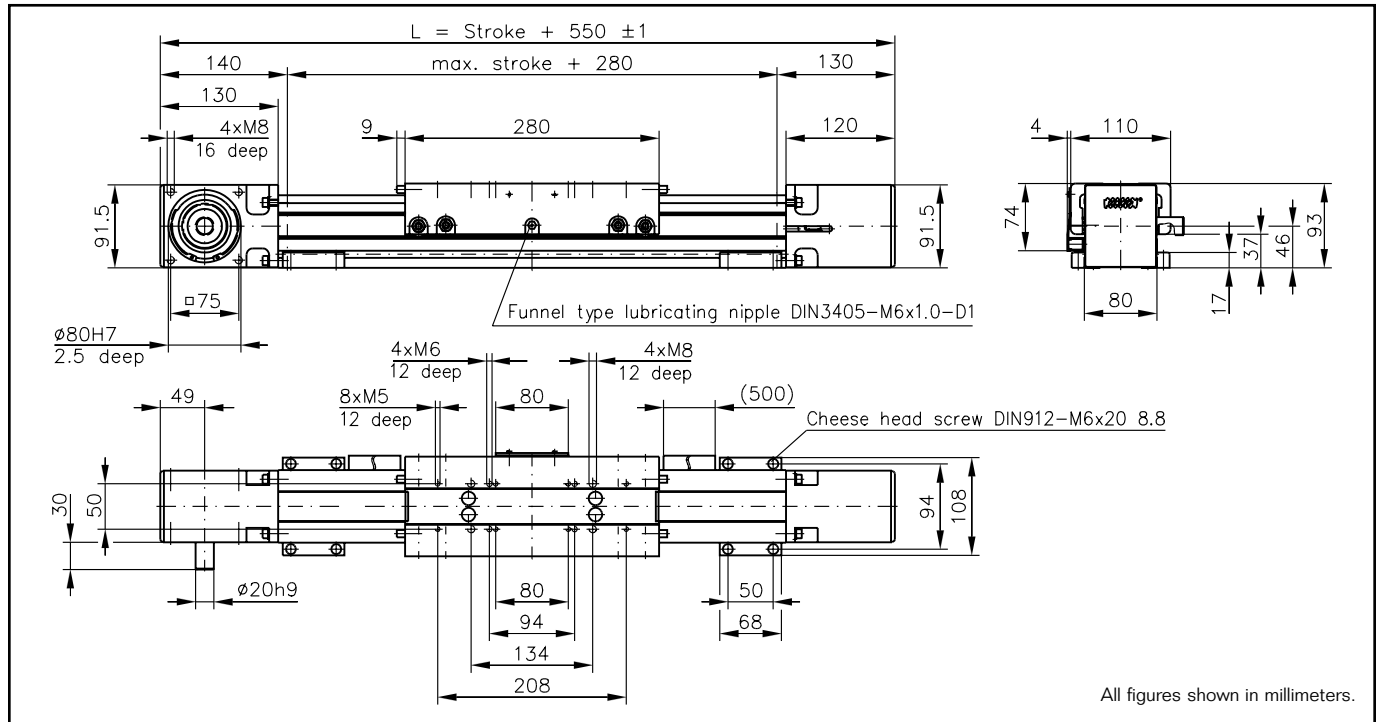

Note: Mounted wipers on request. The use of a long power bridge increases the total length.

Technical data

Linear speed:max. 10 m/s
 Repeatability:± 0.05 mm
 Acceleration:max. 40 m/s²
 Drive element:Toothed belt 32ATL10
 Diameter:63.66 mm
 Stroke per revolution:200 mm
 Stroke length:up to 11000 mm
 Length of power bridge:280 or 450 mm
 see page 28
 Geometrical moment of inertia:ly 1.93 x 10⁸ mm⁴
 lz 1.80 x 10⁸ mm⁴

Weights

Basic unit with zero stroke:8.63 kg
 100 mm stroke:0.93 kg
 Power bridge with carriage:2.75 kg
 Provided:4 pieces KAO mounting
 brackets

Loads and load moments

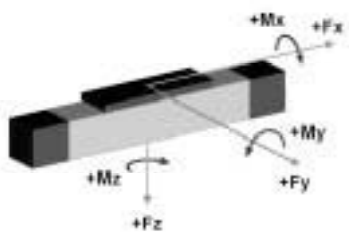

Load	dynam. [N]
Fx drive ¹⁾	max. 2700
Fy	882
±Fz	2100
Load moment	dynam. [Nm]
Mx	75
My ²⁾	230
Mz ²⁾	100

1) Depending on the speed, see respective chart.
 2) Increase of the admissible values by the use of a long power bridge or additional free-sliding power bridge (pages 28 and 29).

Idle torques [Nm]

Rotational speed [rpm]	Middle [Nm]
150	2.4
1500	3.5
3000	5.0

Execution of drive shafts

(Detailed description see pg 55)
 Other executions on request.

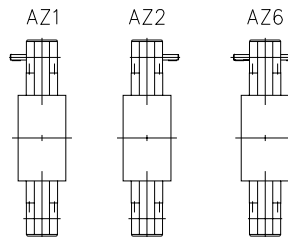

Unit conversions

Length:

1 m=1000 mm=39.37 inches
 1 inch=25.4 mm

Force:

1 N=0.225 lbf
 1 lbf=4.45 N

Moment of Force:

1 Nm=0.738 lb · ft=8.85 lb · inches
 1 lb · ft=1.36 Nm

Geometrical moment of inertia:

1 m⁴=10¹² mm⁴=2.4025 x 10⁶ in⁴

Mass moment of inertia:

1 kg · m²=10⁴ kg · cm²=0.738 lb · ft · s²

Mass:

1 kg=2.2 lb

Fx depending on the linear speed

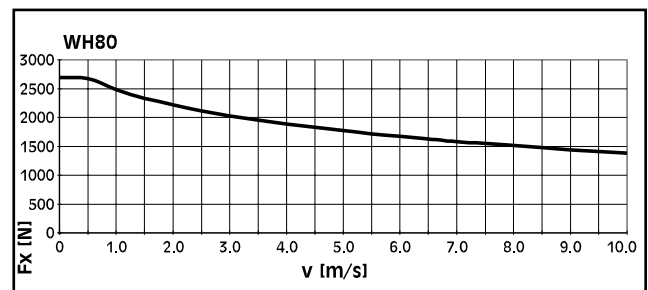

Note: For tube lengths of 5400 mm and over, the tubular profile is composed of two parts. The joint must be adequately supported. It may be possible to position the joint according to customer's wishes.

WIESEL™ SPEEDLine®

New technology right to the center.

WIESEL™ SPEEDLine® WH40

A linear drive unit for dynamic miniaturized applications. High performance with extremely small dimensions.

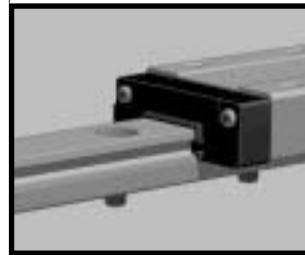
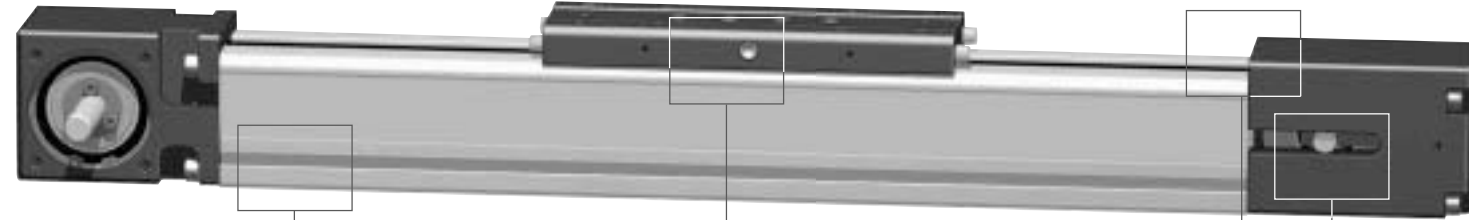

Linear guides

Precise positioning is made possible by a polished linear guide with a high degree of guide accuracy. A smaller motor can be added thanks to the low coefficient of friction. Rubber wipers protect the mechanism from dirt, thus increasing service life.

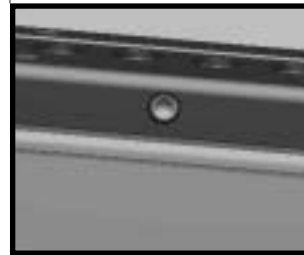

Central lubrication

The linear guide system is conveniently relubricated from a central point. Whether by hand or automatically, maintenance is now a simple matter.

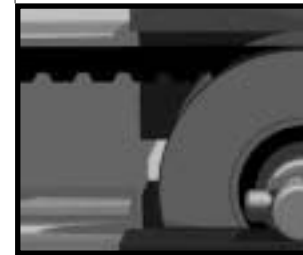

AT toothed belt

A proven drive element:

- high loading
- wear resistance
- high efficiency
- exact spacing
- low mass



Completely new arrangement of the roller guideway

The H-Type arrangement of guidance allows high forces and moments and thereby the choice of a smaller size. Your benefit: lighter and more economical constructions.

Powered by ATL belt

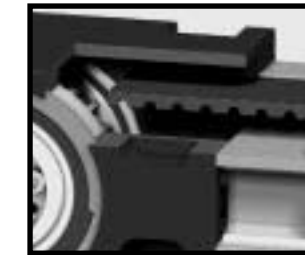

ATL toothed belt

- with steel reinforcement especially suitable for linear drive units
- higher performance
- repeatability of ± 0.05 mm even at high feed forces

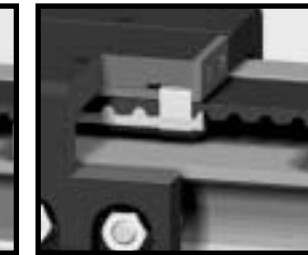

Tension and exchange of toothed belt

The toothed belt can be retensioned and exchanged comfortably without dismounting the load (only WH50/80/120), thus reducing your service costs.

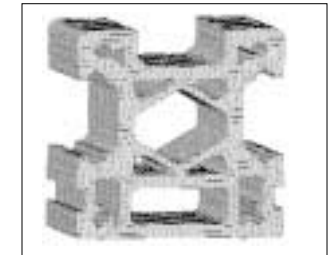
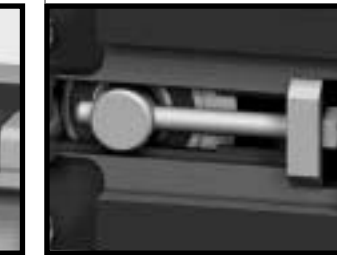

FEA optimized design

FEA analysis helps model and optimize the profile and the whole linear axis. The result: highest performance and reliability.

WIESEL™ SPEEDLine® WH50, WH80, WH120, WHZ50, WHZ80

With the WIESEL™ SPEEDLine® single-axle solutions can be realized as well as two- and three-dimensional handling systems.

The WIESEL™ SPEEDLine® Z-axis is especially suitable for vertical movements. The reduced mass to be moved together with the short design allow higher dynamics and loads.



General technical data

WIESEL™ SPEEDLine®

Speeds

The linear speed achieved by a linear drive unit depends on the lead of the mechanical drive element and on the input rotational speed. The various linear speeds which can be achieved by the individual sizes are listed in the following table:

Size	Lead [mm/rev.]	n_{\max} [rpm]	v_{\max} [m/s]
WH40	100	1800	3
WH50/WHZ50	120	3250	6.5
WH80/WHZ80	200	3000	10
WH120	260	2308	10

Installed position

The linear drive units can basically be installed in any position, provided that all the forces and moments occurring remain below the maximum values for the axis concerned.

Security advice

All sizes are generally *not self-locking*. It is therefore advisable to install suitable motors with holding brakes, particularly if the linear drive unit is installed vertically.

In case of a break of the toothed belt the load is released by toothed belt driven linear units. Therefore safety precautions have to be taken for applications which are critical with regard to security.

Loading

All specified maximum forces and moments refer to the center/top of the power bridge. Load overlay at several coordinates: If compound loads occur, with force and moment components in more than one direction, the maximum permissible loads must be reduced to 60% of the specified maximum values. When forces and moments are overlaid in two or three coordinates, it is necessary to reduce the maximum permissible load to 60% of the maximum value.

Load ratings

See page 96

Operating hours

The toothed belt as well as the roller guide-way allow continuous operation up to 100%. Extremely high loads, combined with long operating hours, may reduce the lifetime.

Temperatures

All series are designed for continuous operation at ambient temperatures up to 80°C (176°F). Temperatures up to 100°C (212°F) are also permitted for brief periods. The linear drive units are not suitable for operation at subzero temperatures.

Idle torque

The indicated values for the idle torque are mean values determined in a rank. In individual cases these values can deviate.

Straightness/torsion

The aluminum profiles are extruded sections which may display deviations in straightness and torsion due to their manufacturing process. The tolerance of these deviations is defined in DIN 17615. The deviations found in Precision Technology USA, Inc. linear drive units correspond to these limits at least, but are normally well below. In order to obtain the required guide accuracy, the linear drive unit must be aligned with the aid of levelling plates or clamped from a mounting surface machined with sufficient accuracy. This ensures that tolerances of at least 0.1 mm/1000 mm are achieved.

Guide tube

A guide tube contains all elements of a linear drive unit except the mechanical drive element. It serves mainly as a support and holding device for higher loads and moments. For this purpose it is either mounted on the backside of a driven WIESEL™ or installed parallel to it. All WIESEL™ models are also available as guide tubes with guide.

Stroke lengths

The stroke length specified in the order code represents the maximum possible linear displacement. Acceleration and deceleration paths must be taken into account when designing the system, as well as any required over-run.

Repeatability

The repeatability is defined as the capability of a linear drive to get back to an actual position which was reached under the same conditions within the given tolerances. It refers to the average position variation

according to VDI/DGQ 3441. The repeatability among others is influenced by:

- Load
- Speed
- Deceleration/acceleration
- Direction of travel
- Temperature

Aggressive working conditions

Because of their tough design WIESEL™ SPEEDLine® units can be used even in rough surroundings without additional covering. As a protection against coarse dirt optional wipers can be used. In case of extreme dirt, or fine dust/filings, a protective bellow is recommended and provided on request.

Maintenance

Lubrication WH40

The linear guide must be lubricated via the grease nipple on the power bridge with the aid of a grease gun after 400 hours of operation or at least every 3 months. Grease: rolling bearing grease (original grease: Fuchs Lubritech URETHYN E/M2).

Lubrication WH50/80/120

To maximize the life of the guide system, the two guides should be permanently covered with a thin oil film. The two lubrication points which are arranged at the sides of the power bridge serve for lubrication.

Tensioning of toothed belt

The tension of the toothed belt can be adjusted with the aid of the tensioning screws on the guide casing which are intended for this. The linear units are delivered with optimal tension values in order to guarantee security in function. Changes in this adjustment must only be carried out in service cases and by Precision Technology USA, Inc. service engineers.

Pretensioning of the guide system

The WIESEL™ units leave the factory with optimal preloading values which guarantee optimum traveling characteristics as well as the necessary capacity in forces and moments. Changes in the preloading of the rollers must only be carried out after prior consultation with Precision Technology USA, Inc. service engineers.

Accessories for WIESEL™ SPEEDLine®

Felt wipers/Mounting brackets

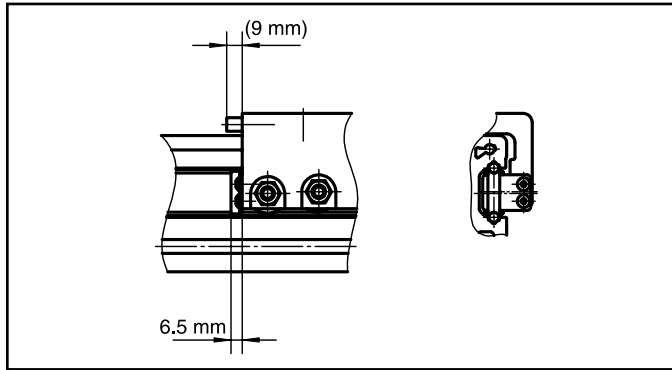

Felt wipers FA for WH50/80/120

The felt wipers are positioned directly in front of each of the rollers at the front next to the power bridge, so that they wipe coarse dirt off the guide shaft. This prevents dirt from being trapped between the roller and the guide rail. This means that the WIESEL™ SPEEDLine® units can also be used in environments in which the guide shafts are exposed to excessive dirt. Installing the felt wipers may increase the driving torque slightly. There is no loss of stroke length and no additional external interference contour. As a result, the felt wipers can also be fitted to existing systems as an optional extra.

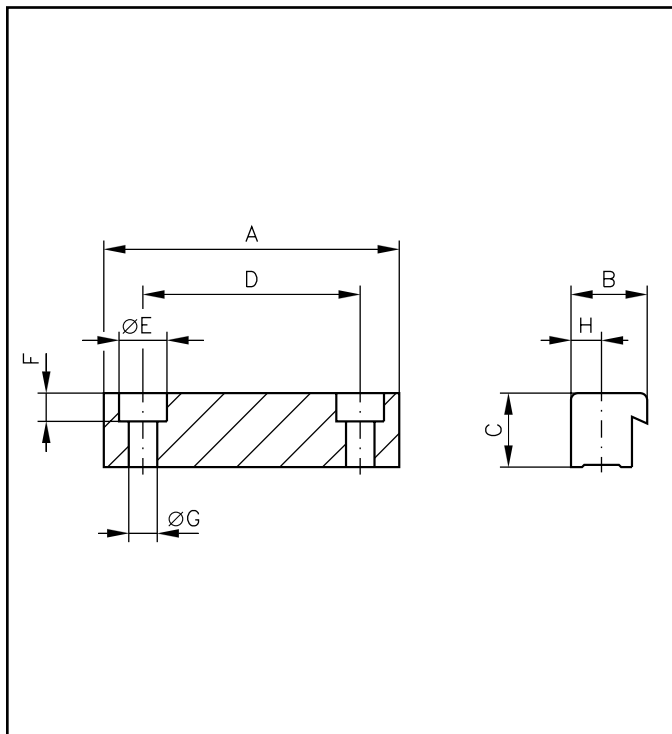

Mounting brackets KAO

The mounting brackets KAO secure the WIESEL™ unit to a mounting surface. They are inserted in the grooves provided in the sides of the tubular aluminum profile and screwed onto the mounting surface with the aid of cheese head screws. The number of mounting brackets required depends on the load and overall length of the WIESEL™ unit. Increasing side forces reduces the admissible distance between the brackets.

4 pieces of mounting brackets are delivered with each unit.

System brackets KAO

Only needed for WH40. With multi-coordinate arrangements of several WIESEL™ units, this can be used to screw a WIESEL™ unit directly to the power bridge of a unit positioned immediately below it.

Moment of tightening screws

Size	Moment [Nm]
WH40	7.3–12
WH50	7.3–12
WH80	7.3–12
WH120	17–30

Note: It is advisable to secure the linear drive unit at intervals of at least 750 mm. This ensures that all the permissible loads can be absorbed without significantly deforming the tubular aluminum profile.

Size	Dimension [mm]								
	A	B	C	D	Ø E	F	Ø G	H	
WH40	54	16	10	40	10	5.7	5.5	7	
WH50	54	16	10	40	10	5.7	5.5	7	
WH80	68	17.5	17	50	11	6.5	6.6	7	
WH120	80	25	18	50	15	8.5	9	10	
WH40 System KAO	40	16	10	26	10	5.7	5.5	7	

Unit conversions

Length:	1 m=1000 mm=39.37 inches 1 inch=25.4 mm
Force:	1 N=0.225 lbf 1 lbf=4.45 N
Moment of Force:	1 Nm=0.738 lb • ft=8.85 lb • inches 1 lb • ft=1.36 Nm

Geometrical moment of inertia:	1 m ⁴ =10 ¹² mm ⁴ =2.4025 × 10 ⁶ in ⁴
Mass moment of inertia:	1 kg • m ² =10 ⁴ kg • cm ² =0.738 lb • ft • s ²
Mass:	1 kg=2.2 lb

Accessories for WIESEL™ SPEEDLine®

Long power bridge

SPEEDLine

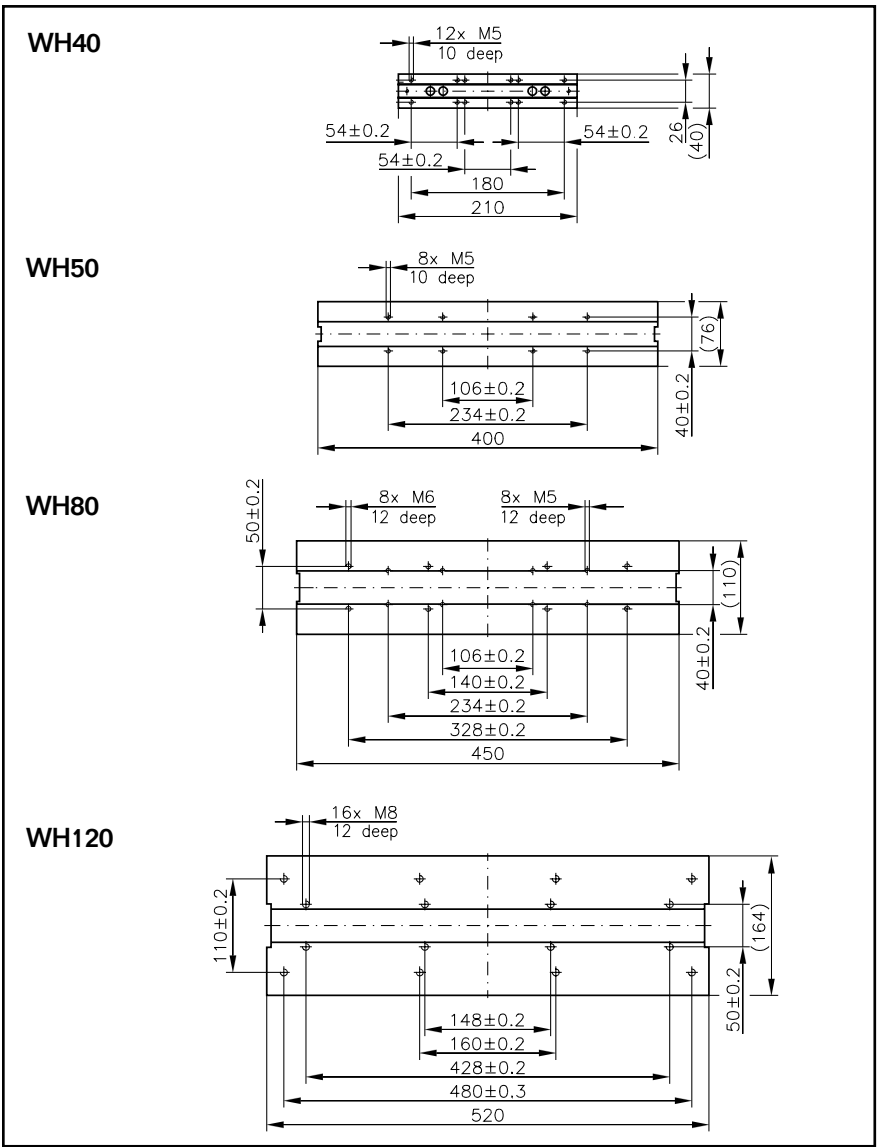

All figures shown in millimeters.

Long power bridge LKB

The long power bridge increases the maximum permissible load moments M_y and M_z of a WIESEL™ unit without requiring a step up in size. The difference in length between the long power bridge and the standard power bridge must be taken into account when calculating the overall length of the WIESEL™ unit.

Overall length of the WIESEL™ unit:

$$L_{tot} = \text{stroke} + L_c + \Delta K_b$$

- L_{tot} = Overall length WIESEL™ [mm]
- L_c = Specific additional length [mm]
(see technical data of the respective WIESEL™)
- Stroke** = Required stroke [mm]
- ΔK_b = Difference in length between long and standard power bridge

Size	Length of power bridge [mm]	M_y [Nm]	M_z [Nm]
WH40	210	50	50
WH50	400	130	75
WH80	450	345	150
WH120	520	1395	750
WHZ50	400	130	75
WHZ80	450	345	150

Note: All other limit values are comparable to those of versions with standard power bridge. High load moments lead to major deformation of the tubular aluminum profile. The distance between supports should be reduced in order to minimize this deformation.

Unit conversions

Length:	1 m=1000 mm=39.37 inches 1 inch=25.4 mm	Geometrical moment of inertia:	1 m ⁴ =10 ¹² mm ⁴ =2.4025 x 10 ⁶ in ⁴
Force:	1 N=0.225 lbf 1 lbf=4.45 N	Mass moment of inertia:	1 kg · m ² =10 ⁴ kg · cm ² =0.738 lb · ft · s ²
Moment of Force:	1 Nm=0.738 lb · ft=8.85 lb · inches 1 lb · ft=1.36 Nm	Mass:	1 kg=2.2 lb

Accessories for WIESEL™ SPEEDLine®

Additional free-sliding power bridge

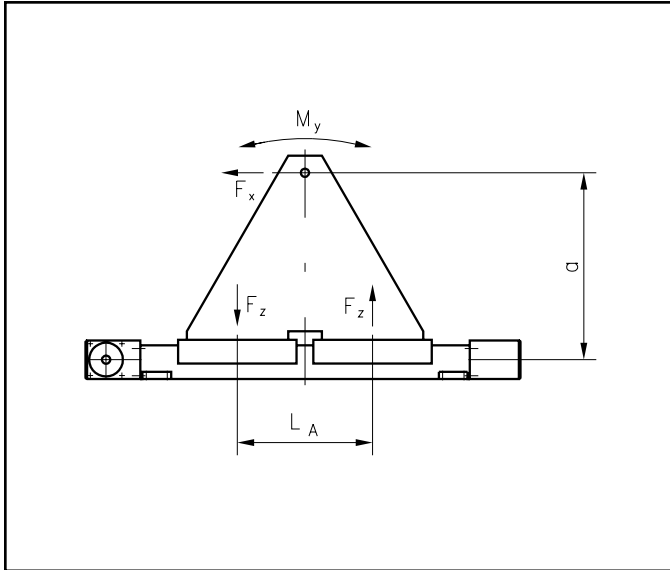

Additional free-sliding power bridge OKB

The additional free-sliding power bridge provides:

- Individual increase of the load moments M_y and M_z of a WIESEL™ unit. Load moment M_y is limited by force $\pm F_z$, M_z is limited by force $\pm F_y$.
- Longer and therefore improved guidance.
- Particularly suitable as a vertical guide and lifting module. The required center distance between the driven and the free-sliding power bridge is calculated as follows:

$$L_A = \frac{M}{F_{\max}}$$

- L_A = Center distance between driven and free-sliding power bridge [mm]
 M = Load moment M_y or M_z [Nm]
 F_{\max} = Maximum force F_z or F_y of the WIESEL™ unit concerned [N]

The center distance between the two power bridges must be taken into account when calculating the overall length of the WIESEL™ unit.

Overall length of WIESEL™ unit:

$$L_{\text{tot}} = \text{Stroke} + L_c + L_A$$

L_c = Specific additional length between long and standard power bridge [mm]. (see technical data of the respective WIESEL™)

Minimum center distance L_A between driven and free-sliding power bridge (given for standard power bridge).

Size	L_A [mm]
WH40	130
WH50/WHZ50	250
WH80/WHZ80	290
WH120	290

The force required for moving the additional free-sliding power bridge must be taken into account when selecting the drive.

Size	F [N]
WH40	2
WH50/WHZ50	16
WH80/WHZ80	20
WH120	30

Note: High load moments lead to major deformation of the tubular aluminum profile. The distance between supports should be reduced in order to minimize this deformation.

Unit conversions

Length:	1 m=1000 mm=39.37 inches 1 inch=25.4 mm
Force:	1 N=0.225 lbf 1 lbf=4.45 N
Moment of Force:	1 Nm=0.738 lb · ft=8.85 lb · inches 1 lb · ft=1.36 Nm

Geometrical moment of inertia:	1 m ⁴ =10 ¹² mm ⁴ =2.4025 × 10 ⁶ in ⁴
Mass moment of inertia:	1 kg · m ² =10 ⁴ kg · cm ² =0.738 lb · ft · s ²
Mass:	1 kg=2.2 lb

Examples

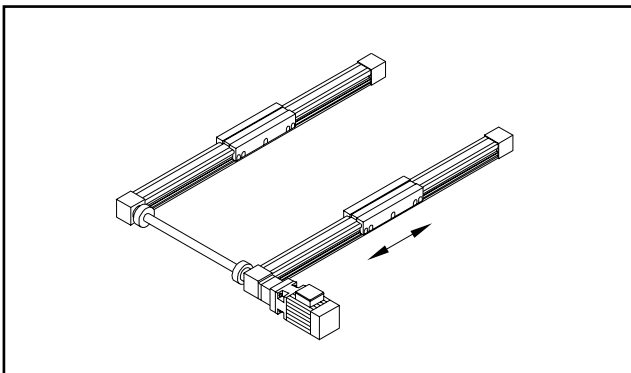

- Parallel arrangement:**
2 WIESEL™ *SPEEDLine*®
1 Universal joint shaft
1 Drive package

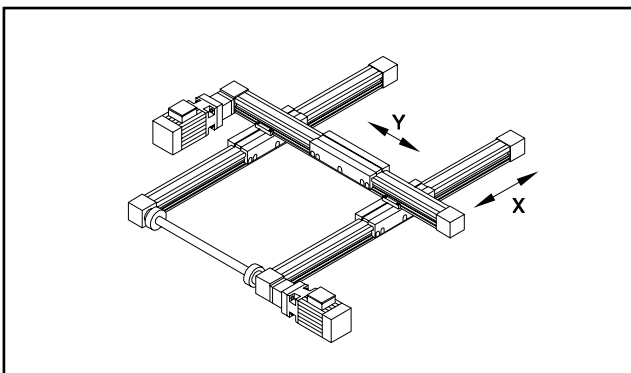

- 2-axis arrangement:**
X-axis:
2 WIESEL™ *SPEEDLine*®
1 Universal joint shaft
1 Drive package
Y-axis:
1 WIESEL™ *SPEEDLine*®
1 Drive package

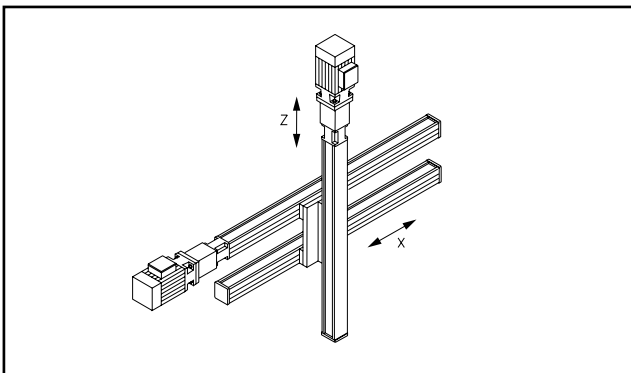

- 2-axis arrangement:**
X-axis:
1 WIESEL™ *POWERLine*®
1 WIESEL™ *POWERLine*® as guide tube
1 Drive package
Z-axis:
1 WIESEL™ *POWERLine*®
1 Drive package

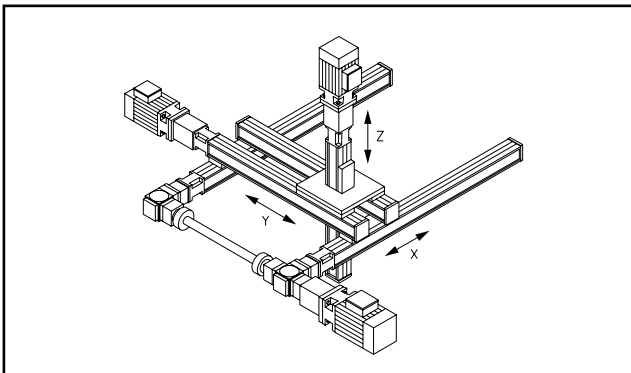

- 3-axis arrangement:**
X-axis:
2 WIESEL™ *POWERLine*®
with bevel gearbox
1 Universal joint shaft
1 Drive package
Z-axis:
1 WIESEL™ *POWERLine*®
1 Drive package
Y-axis:
1 WIESEL™ *POWERLine*®
1 WIESEL™ *POWERLine*® as
guide tube
1 Drive package

Load ratings WIESEL™

Dynamic load ratings

With the help of dynamic load ratings, it is possible to calculate the approximate lifetime, dependent on load. The figures shown are for the KGT, according to DIN 69051, Part 4, Draft 1989, and for the guide, according to DIN 636.

Type	C _{KGM} P=4 [N]	C _{KGM} P=5 [N]	C _{KGM} P=10 [N]	C _{KGM} P=20 [N]	C _{KGM} P=40 [N]	C _{KGM} P=50 [N]	C _{FS} Y [N]	C _{FS} Z [N]	L _{FS} X [mm]	L _{FS} Y [mm]
WH40	–	–	–	–	–	–	(2x) 2786	(2x) 3397	72	–
WH50	–	–	–	–	–	–	–	(4x) 1270	198	39
WH80	–	–	–	–	–	–	–	(4x) 3670	220	65
WH120	–	–	–	–	–	–	–	(4x) 16200	180	97
WHZ50	–	–	–	–	–	–	–	(4x) 1270	198	39
WHZ80	–	–	–	–	–	–	–	(4x) 3670	220	65
WM40	–	2393	–	–	–	–	(2x) 2786	(2x) 3397	87	–
WM60-370 ZRT	–	–	–	–	–	–	(2x) 12964	(2x) 11934	–	35
WM60-370	–	7552	–	8312	–	4677	(2x) 12964	(2x) 11934	–	35
WM60	–	7552	–	8312	–	4677	(4x) 11495	(4x) 10581	141.7	35
WM60-500	–	7552	–	8312	–	4677	(4x) 11495	(4x) 10581	141.7	35
WM80-370 ZRT	–	–	–	–	–	–	(2x) 18723	(2x) 17919	–	49.75
WM80 ZRT	–	–	–	–	–	–	(4x) 14356	(4x) 13739	153	49.75
WM80-370	–	8804	9311	9365	–	8572	(2x) 18723	(2x) 17919	–	49.75
WM80	–	8804	9311	9365	–	8572	(4x) 14356	(4x) 13739	154	49.75
WM120	–	15429	24049	20667	8341	–	(4x) 18723	(4x) 17919	186	80.75
WV60	–	7552	–	8312	–	4677	–	–	–	–
WV80	–	8804	9311	9365	–	8572	–	–	–	–
WV120	–	15429	24049	20667	8341	–	–	–	–	–

Important note: The permissible force and moment threshold values for the respective linear unit must not be exceeded at any time.

Unit conversions

Length: 1 m=1000 mm=39.37 inches
1 inch=25.4 mm

Force: 1 N=0.225 lbf
1 lbf=4.45 N

Moment of Force: 1 Nm=0.738 lb · ft=8.85 lb · inches
1 lb · ft=1.36 Nm

Geometrical moment of inertia: 1 m⁴=10¹² mm⁴=2.4025 x 10⁶ in⁴

Mass moment of inertia: 1 kg · m²=10⁴ kg · cm²=0.738 lb · ft · s²

Mass: 1 kg=2.2 lb

Drive selection

for linear drive units with toothed belt drive

Feed force
 F_x [N]

$$F_x = m \cdot g \cdot \mu$$

Acceleration force
 F_a [N]

$$F_a = m \cdot a$$

In vertical applications, the mass acceleration a must be added to the acceleration due to gravity g [9.81 m/s²].

Power from torque and rotational speed
[kW]

$$P = \frac{M_A \cdot n_{\max} \cdot 2 \cdot \pi}{60 \cdot 1000}$$

Definitions

M_A = Required drive moment [Nm]

M_{load} = Moment resulting from the various loads [Nm]

M_{idle} = Idle torque [Nm]

M_{rot} = Rotational acceleration moment [Nm]

M_{trans} = Translational acceleration moment [Nm]

F_x = Feed force [N]

F_a = Acceleration force [N]

g = Acceleration due to gravity [m/s²]

v_{\max} = Maximum linear speed [m/s]

m = Mass to be transported [kg]¹⁾

a = Acceleration [m/s²]

d_o = Effective diam. of pulley [mm]²⁾

P = Power [kW]

L = WIESEL™ length [mm]

J_{syn} = Idle torque of pulley [kgm²]

n_{\max} = Maximum rotational speed [rpm]

μ = Friction factor

Calculating the drive moment M_A [Nm]

The required drive moment is composed of the "load moment", the "acceleration moment" and the "idle torque".

$M_A = M_{\text{load}} + M_{\text{trans}} + M_{\text{rot}} + M_{\text{idle}}$

The value for the respective idle torque can be found with the corresponding mechanical linear drive units.

$$M_{\text{rot}} = J_{\text{syn}} \cdot \frac{2 \cdot \pi \cdot n_{\max}}{60} \cdot \frac{a}{v_{\max}}$$

$$M_{\text{trans}} = \frac{F_a \cdot d_o}{1000 \cdot 2}$$

$$M_{\text{load}} = \frac{F_x \cdot d_o}{1000 \cdot 2}$$

$M_A \text{ Total} =$

Type	μ	J_{syn} [kgm ²]	Spec. weight tooth belt [kg/m]
WH40	0.05	8.800 E-06	0.032
WH50	0.1	1.928 E-05	0.055
WH80	0.1	2.473 E-04	0.210
WH120	0.1	1.004 E-03	0.340

Type	μ	J_{syn} [kgm ²]	Spec. weight tooth belt [kg/m]
WHZ50	0.1	6.906 E-05	0.055
WHZ80	0.1	5.026 E-04	0.114

¹⁾ Total weight m = weight to be moved + weight of power bridge ³⁾ + weight of toothed belt
 Weight of toothed belt = spec. weight of tooth belt [kg/m] · 2⁴⁾ · $\frac{\text{WIESEL™ length [mm]}}{1000}$

²⁾ Values for the respective effective diameters, see at corresponding mechanical linear units.

³⁾ For Z-axis moved dead weight to be taken into account.

⁴⁾ To replace by 1 at Z-Axis

Order information

WIESEL™ *SPEEDLine*®

Structure of the order code:

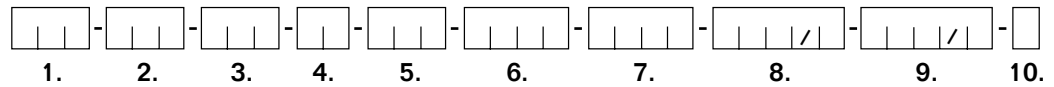

1. Product

WH = Standard axis
WHZ = Z-axis

2. Size

40, 50, 80 and 120¹⁾

3. Design model

000 = Standard
190 = Guide tube

4. Drive type

ZR = toothed belt drive

5. Lead

Size 40 = 100 mm
Size 50 = 120 mm
Size 80 = 200 mm
Size 120 = 260 mm

6. Maximum stroke

[mm]

7. Total length

[mm]

8. Execution of drive shaft

Standard: AZ1, AZ2 and AZ6
(varieties see below)

9. Mounted accessories

EN = Inductive proximity switches²⁾
ES = Mechanical limit switches³⁾
OKB = Additional free-sliding power bridge
LKB = Long power bridge
ADG = Mounted shaft encoder (specify number of pulses and version)
MGK = Mounted motor adapter flange and coupling
FA = Felt wipers³⁾
RT = Belt drive

10. Special execution

0 = No
1 = Yes, description in words

¹⁾ Size 40 and 120 not available as Z-axis

²⁾ Size 50

EN/A = Limit switches mounted on axis
EN/L = Loose kit, enclosed to delivery

³⁾ Not possible for WIESEL™ WH40

WIESEL Ordering

Ordering example:

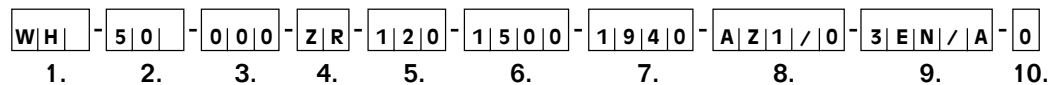

1. Product

WIESEL™ *SPEEDLine*® Standard

2. Size

50

3. Design model standard

Standard

4. Drive type

Toothed belt drive

5. Lead

120 mm/revolution

6. Max. stroke

1500 mm

7. Total length

1940 mm

8. Execution of drive shaft

AZ1/plain

9. Mounted Accessories

3 pieces inductive proximity switches (normally 2 NC and 1 NO) mounted on WIESEL™

10. Special execution

No special execution

Definition of the drive shaft within the order code

Drive shaft execution

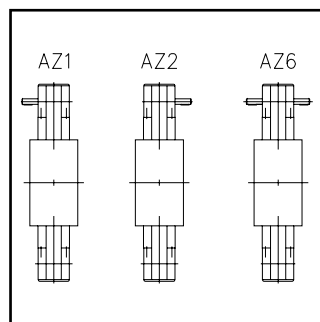

Execution varieties of the drive shaft:

0 = plain
N = with keyway
D = shaft end prepared for mounting of a shaft encoder

Definition of the drive shaft within the order code

Drive shaft execution AZ1
Drive shaft execution AZ2

Example:

AZ6/D/N

Drive shaft execution AZ6, side AZ1 prepared for mounting of a shaft encoder, side AZ2 with keyway.